

Supplementary file

A new near-wellbore modeling method for deviated wells in corner-point grid

Junjian Li¹, Lin Zhao², Olav Møyner³, Knut-Andreas Lie³

¹ *State Key Laboratory of Petroleum Resources and Engineering, China University of Petroleum (Beijing), Beijing 102249, P. R. China*

² *Department of Exploration and Development, CNOOC Research Institute Co., Ltd, Beijing 100027, P. R. China*

³ *Mathematics and Cybernetics, SINTEF Digital, Oslo 0314, Norway*

E-mail address: junjian@126.com (J. Li); zhaolin11@cnooc.com.cn (L. Zhao);

olav.moyner@sintef.no (O. Møyner); Knut-Andreas.Lie@sintef.no (K. -A. Lie).

* Corresponding author (ORCID: 0000-0002-8105-2878 (J. Li))

Li, J., Zhao, L., Møyner, O., Lie, K. -A. A new near-wellbore modeling method for deviated wells in corner-point grid. Advances in Geo-Energy Research, 2025, 15(2): 112-128.

The link to this file is: <https://doi.org/10.46690/ager.2025.02.04>

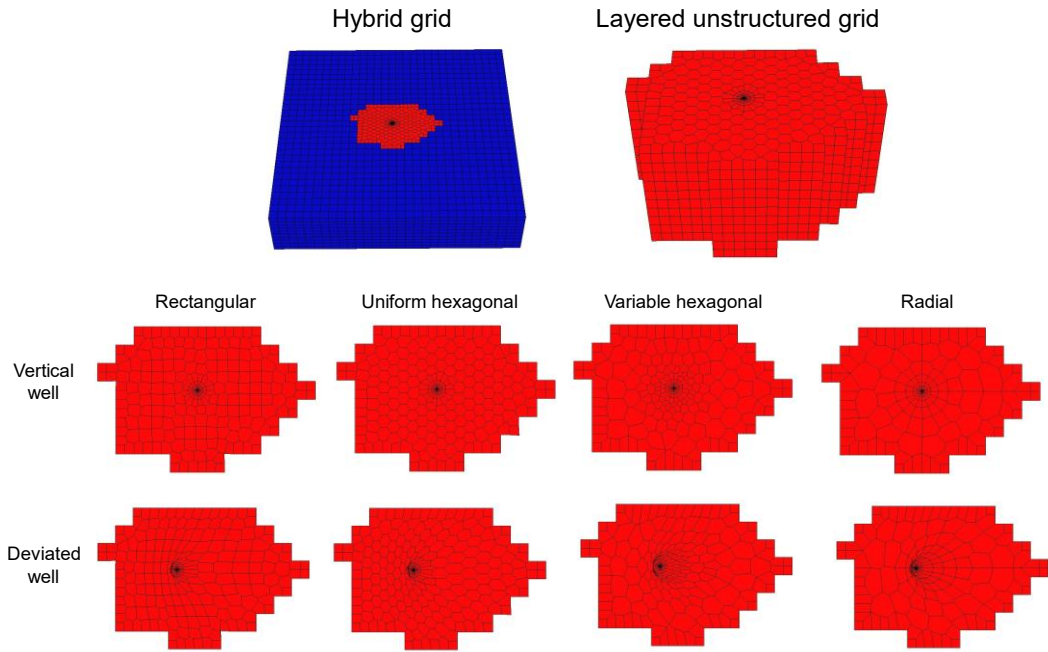

Fig. S1. Illustration of layered unstructured hybrid grid produced by ECLIPSE-NWM.

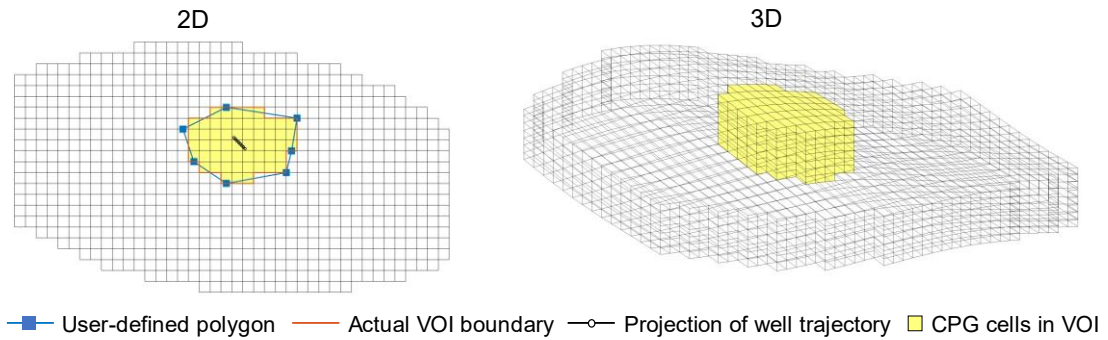

Fig. S2. 2D and 3D illustrations of VOI.

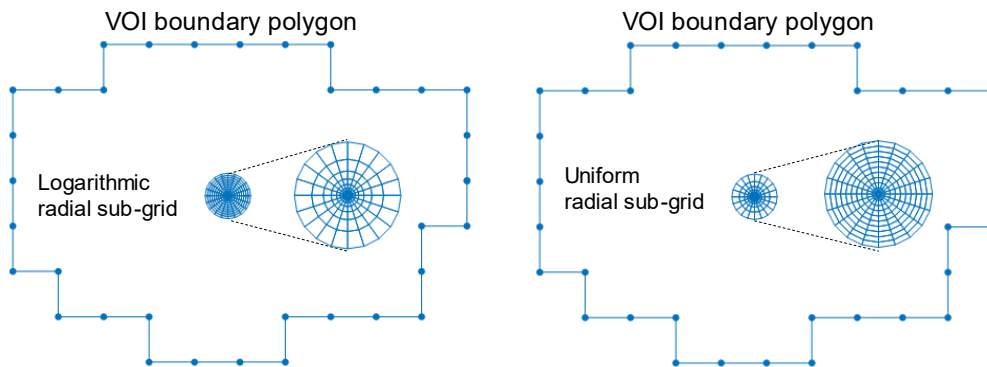

Fig. S3. Radial sub grids in logarithmic node distributions and uniform node distributions.

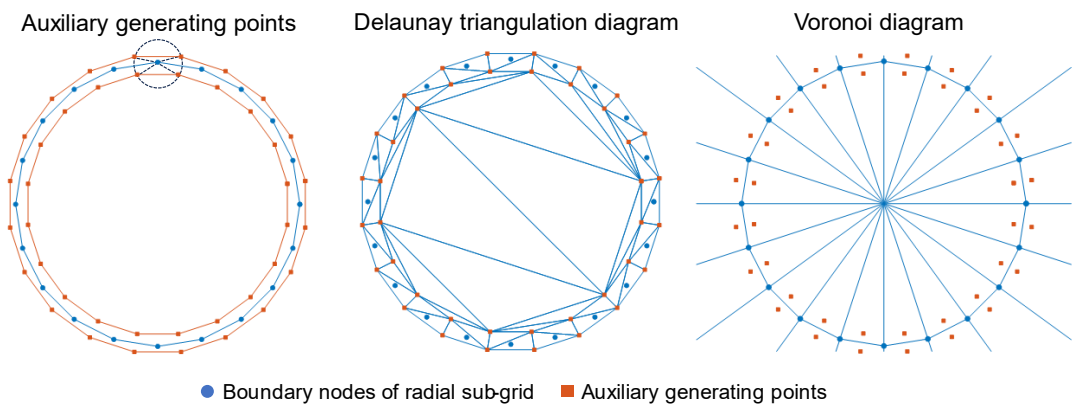

Fig. S4. Auxiliary generating points for reproducing radial sub-grid boundary nodes.

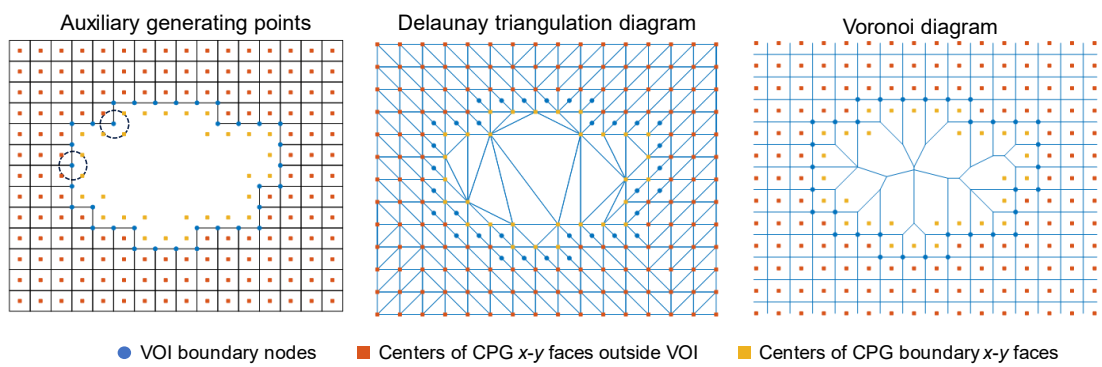

Fig. S5. Auxiliary generating points for reproducing VOI boundary nodes.

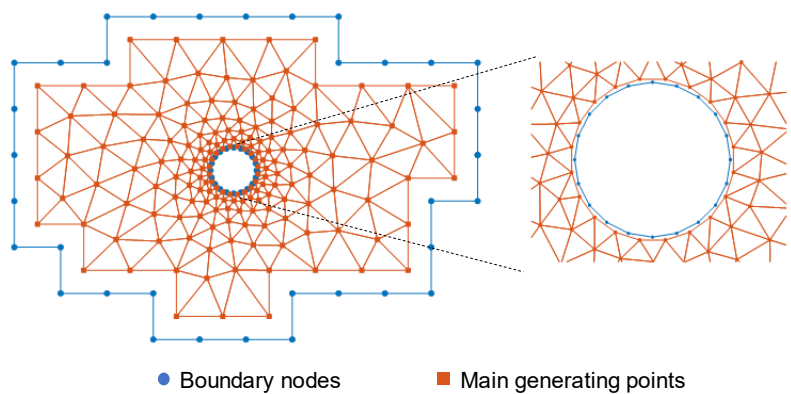

Fig. S6. Main generating points by distmesh algorithm.

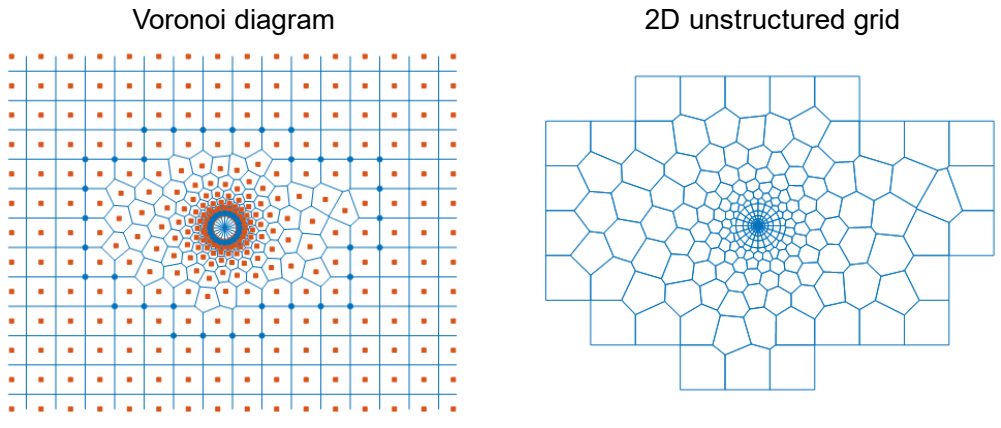

Fig. S7. Voroni diagram and the 2D unstructured grid.

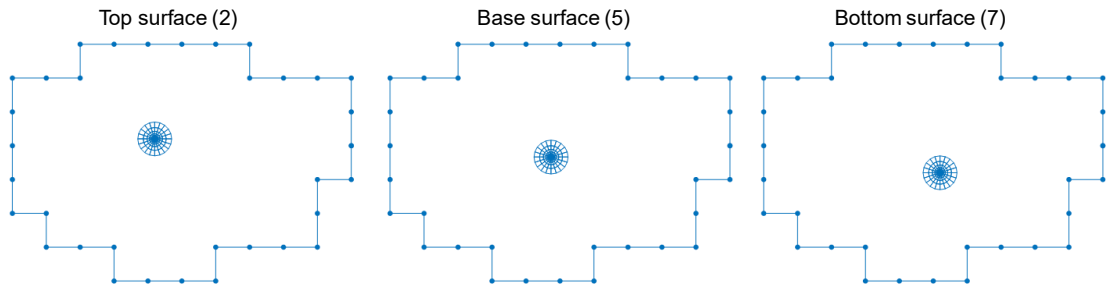

Fig. S8. Radial sub-grid on different surfaces.

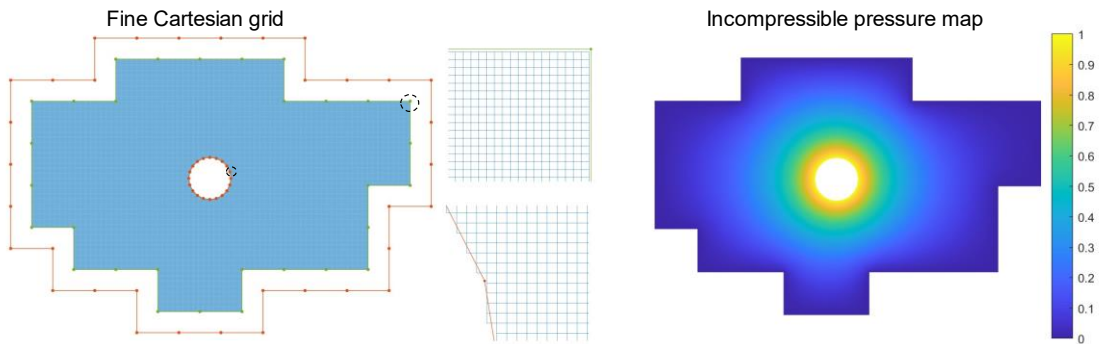

Fig. S9. Illustration of fine grid in Voroni region and incompressible pressure map.

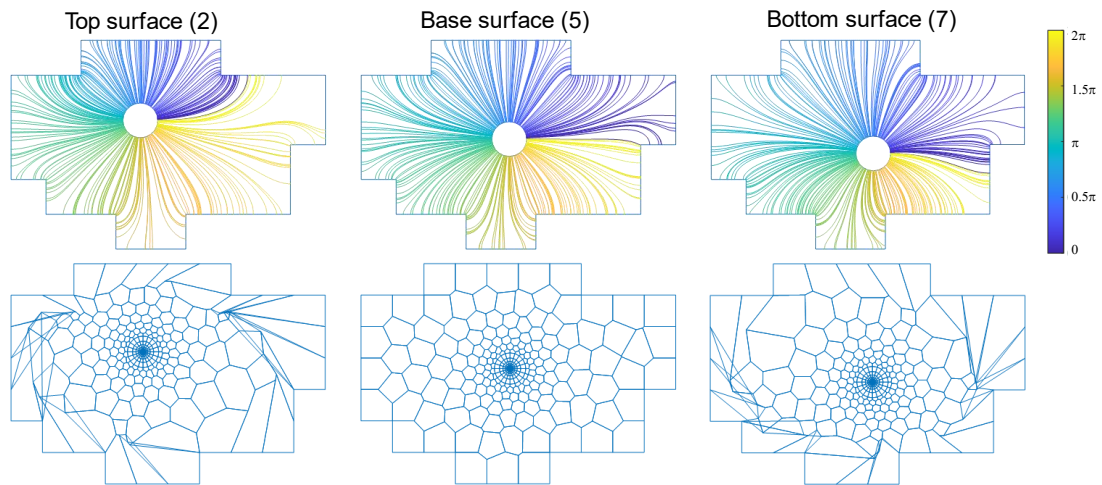

Fig. S10. Forward streamlines and corresponding grids on different surfaces.

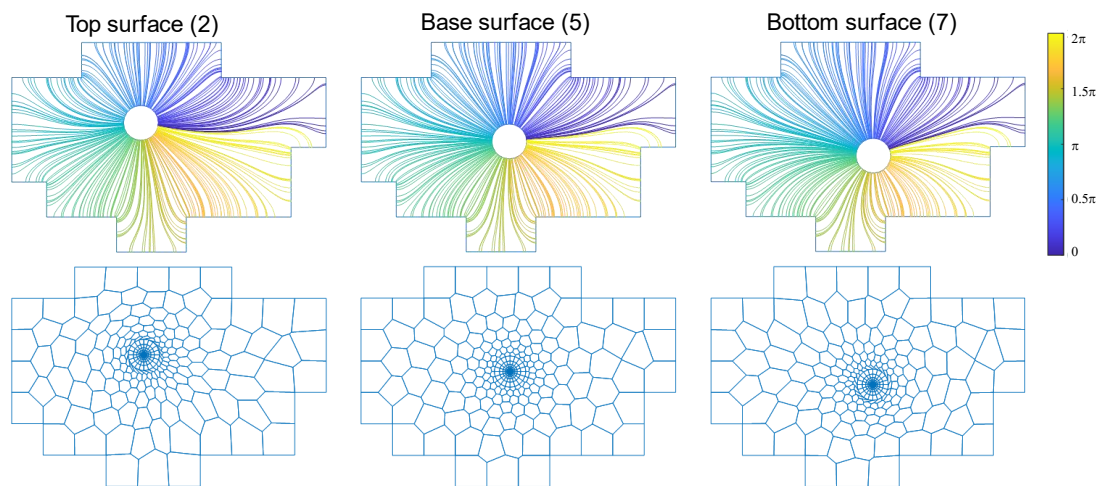

Fig. S11. Backward streamlines and corresponding grids on different surfaces.

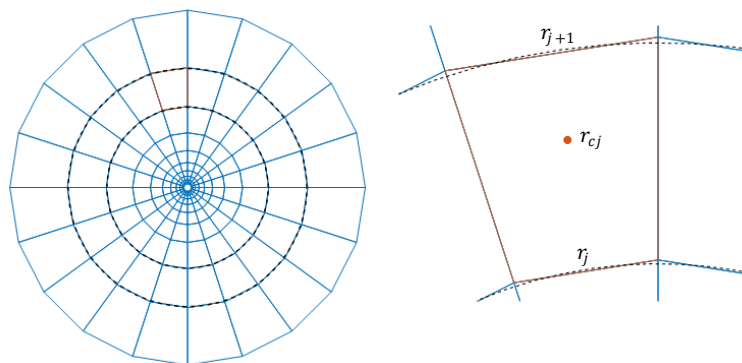

Fig. S12. Geometric representation of transmissibility calculation for radial cells.